

s o v a

---

## Mortuary Trolley

4H803

User Manual

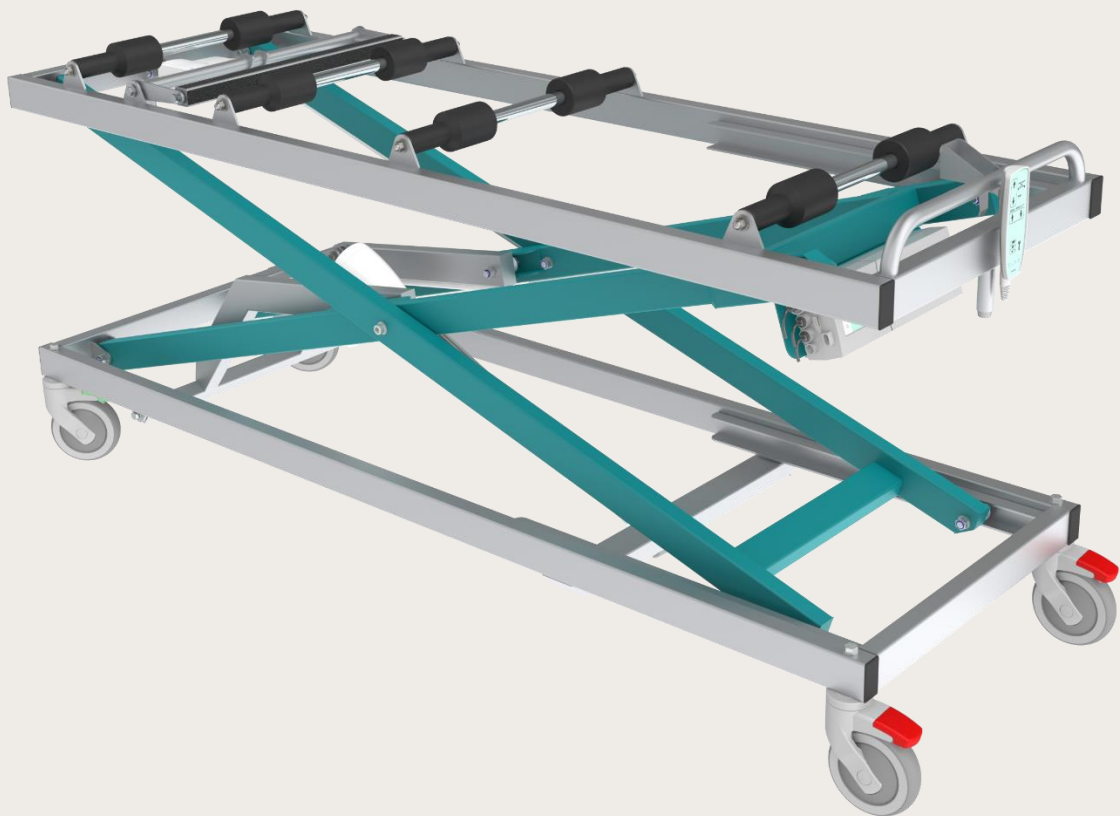

---

dignity in motion

# Table of Contents

<b>1. Overview</b>	<b>2</b>
<b>2. Supplied parts</b>	<b>2</b>
<b>3. Accessories</b>	<b>2</b>
<b>4. Product explanation</b>	<b>3</b>
4.1. Trolley	3
4.2. FEATURES	4
4.3. GENERAL USE	6
4.4. Control box	7
4.5. Handset	7
<b>5. Specifications</b>	<b>8</b>
5.1. SWL	8
5.2. Dimensions	8
<b>6. Safety</b>	<b>8</b>
6.1. General operation	8
6.2. Precautions	8
<b>7. Operation Instructions</b>	<b>9</b>
7.1. Raise & Lower Trolley Operation	9
7.2. Castor Operation	9
7.3. Electric Brake Operation	10
7.4. Connecting & Disconnecting Battery	10
7.5. Charging Battery	11
<b>8. Care &amp; Maintenance</b>	<b>11</b>
8.1. Cleaning	11
8.2. Maintenance	12
<b>9. Transport &amp; Storage</b>	<b>12</b>
9.1. Storage	12
9.2. Transport	12
<b>10. Warranty</b>	<b>13</b>
<b>11. Spare Parts</b>	<b>13</b>

## 1. Overview

The 4H803 Mortuary Trolley is designed for the movement of both coffins and body trays to and from the mortuary unit. A lightweight construction method combined with a unique scissor mechanism allows for a compact length which in turn allows for the optimal use of space with the Mortuary Racking System.

The Coffin/Tray brake is applied via an electric system and operated by pushing a button on the handset.

The trolley is manufactured from the highest quality materials while using the latest in electronic technology to operate the trolley.

## 2. Supplied parts

1x - 4H803 - Mortuary Trolley

1x - Battery

1x - Battery charger

## 3. Accessories

- Battery

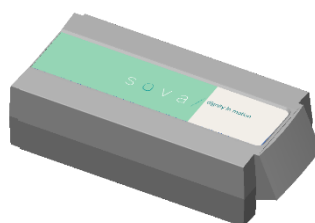

- Body Tray



- Body Tray Racking



## 4. Product explanation

### 4.1. Trolley

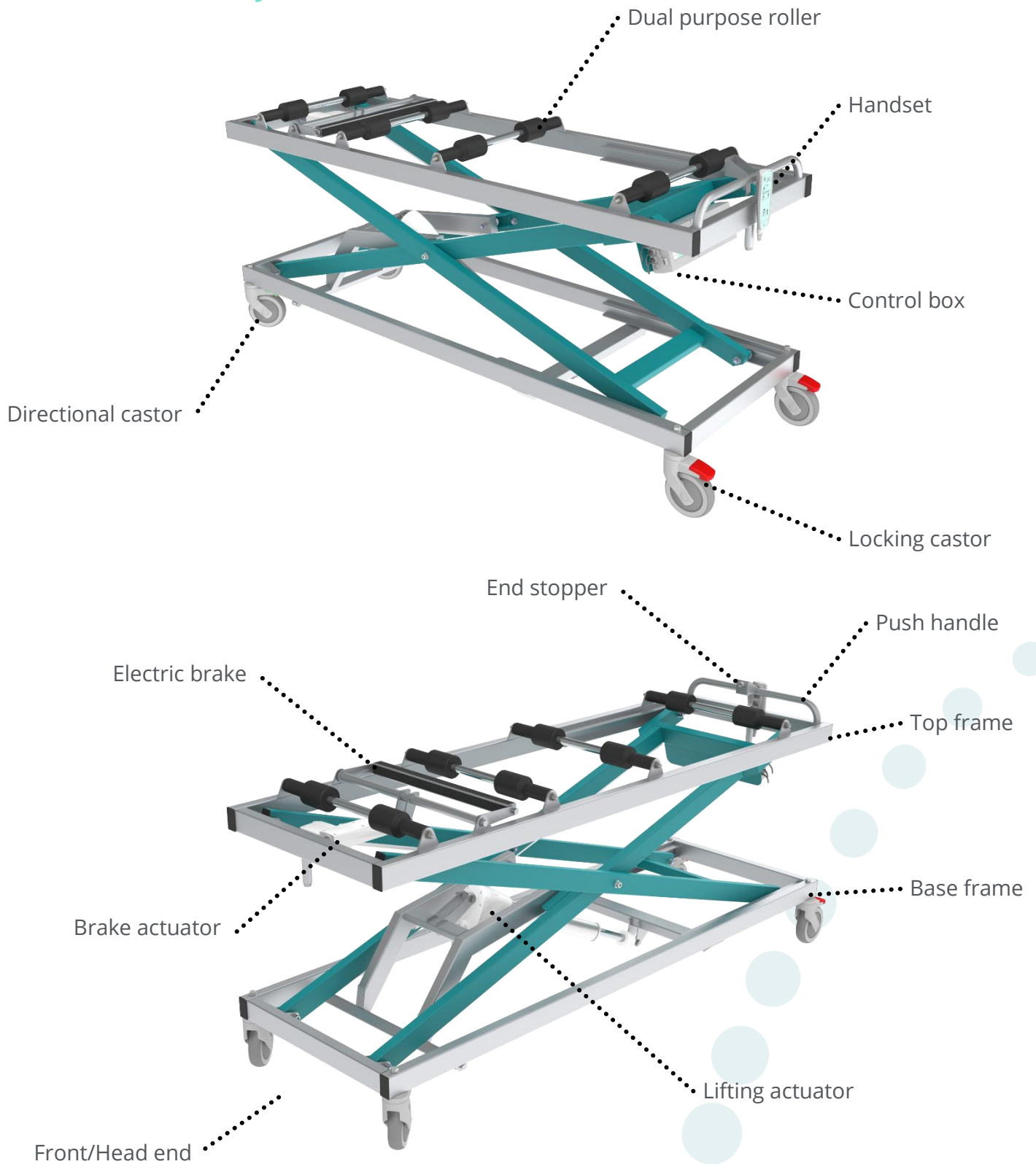

## 4.2. FEATURES

### Electric Brake



### Electric Drain Function

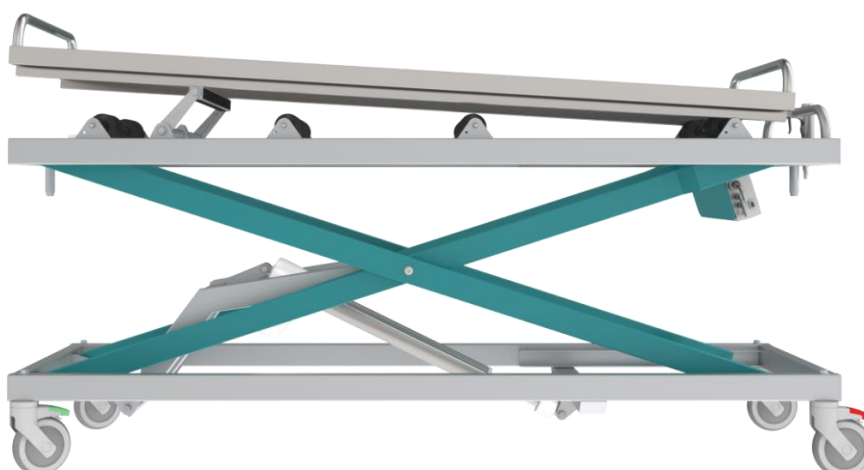

### Multifunction Rollers



## End Stopper

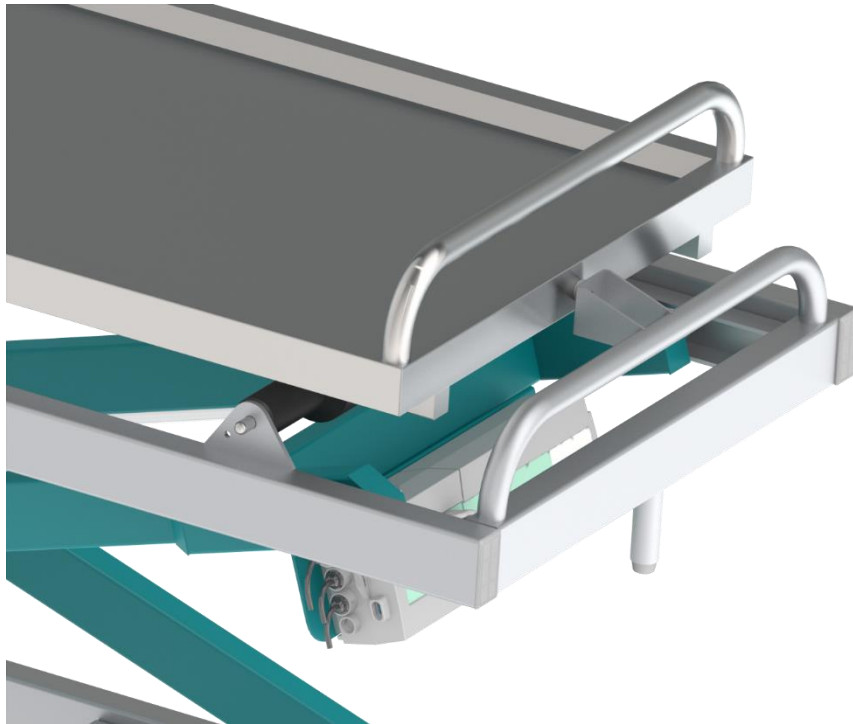

## Height Adjustable Handle

Raise or lower the trolley height to achieve an optimal push height. Ensure trolley height is as low as possible when manoeuvring with body tray or coffin.

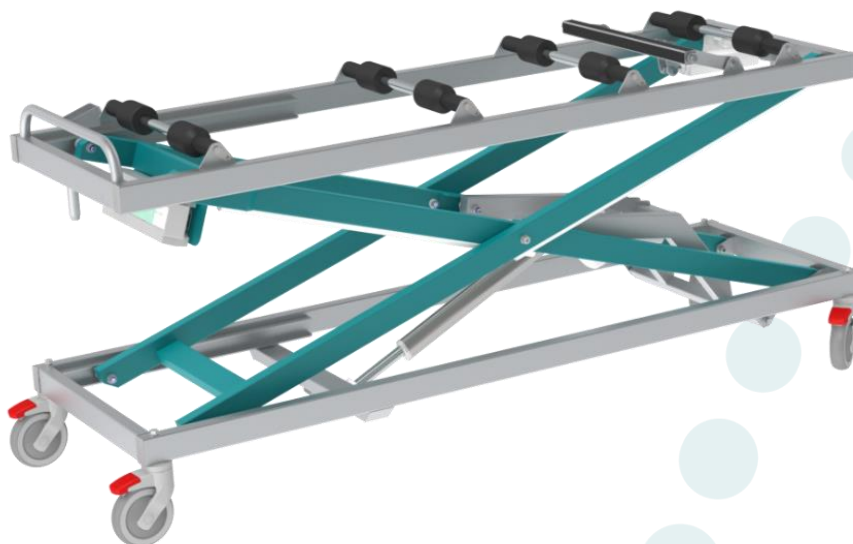

### 4.3. GENERAL USE



Trolley Orientation- Fig.4.3-1

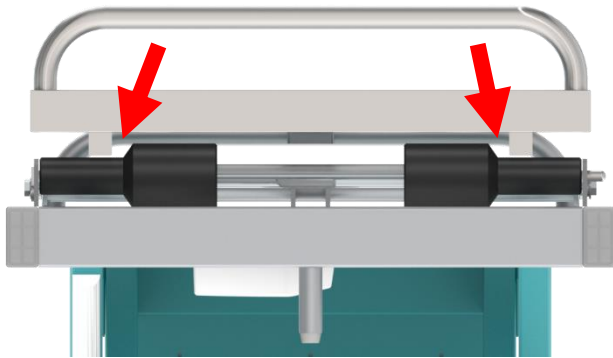

Body Tray Roller Alignment- Fig.4.3-2

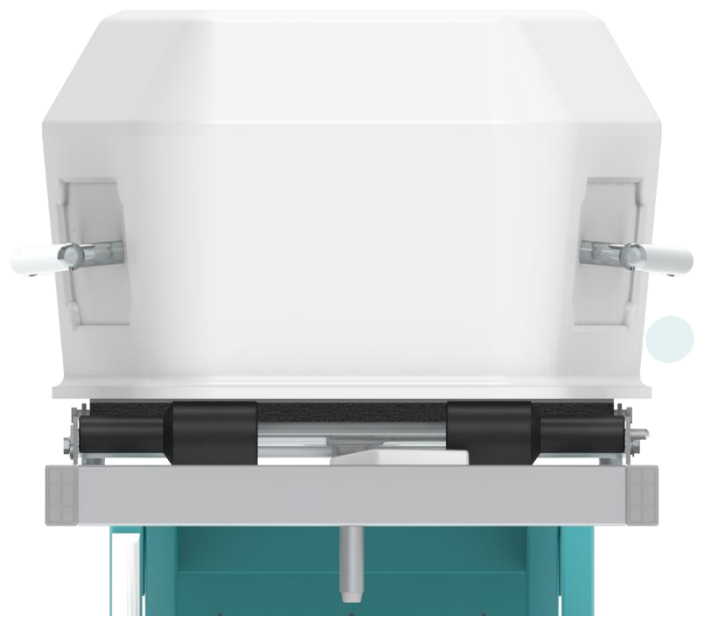

Coffin Roller Alignment- Fig.4.3-2

## 4.4. Control box

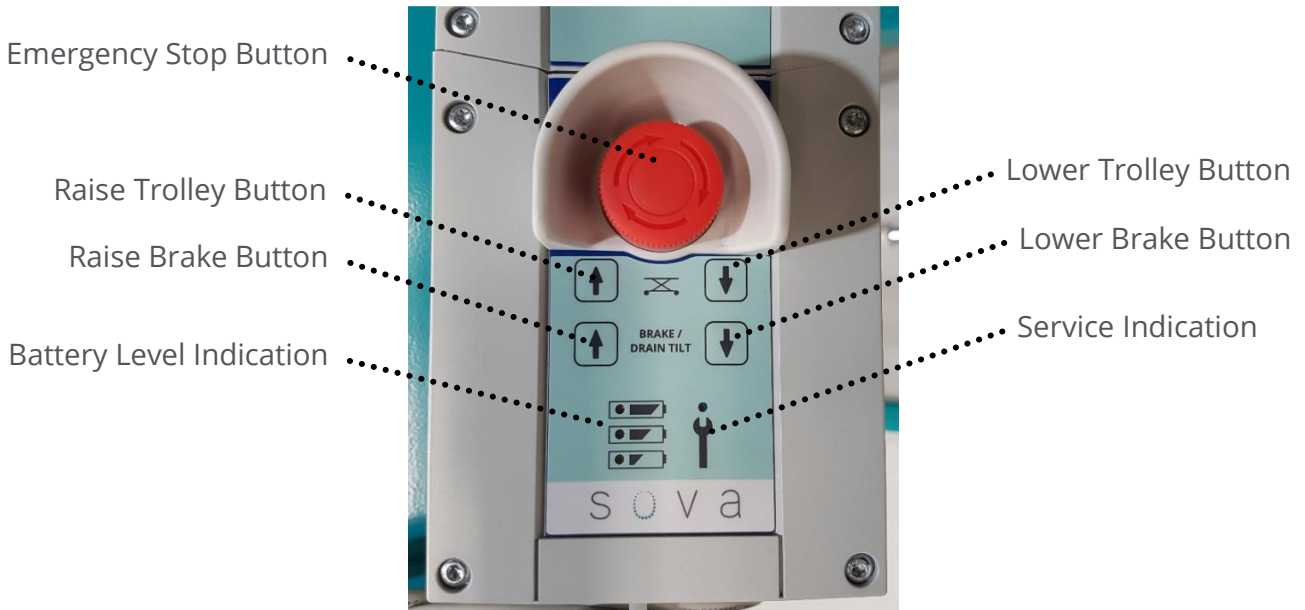

Control Box - Fig. 4.3

## 4.5. Handset

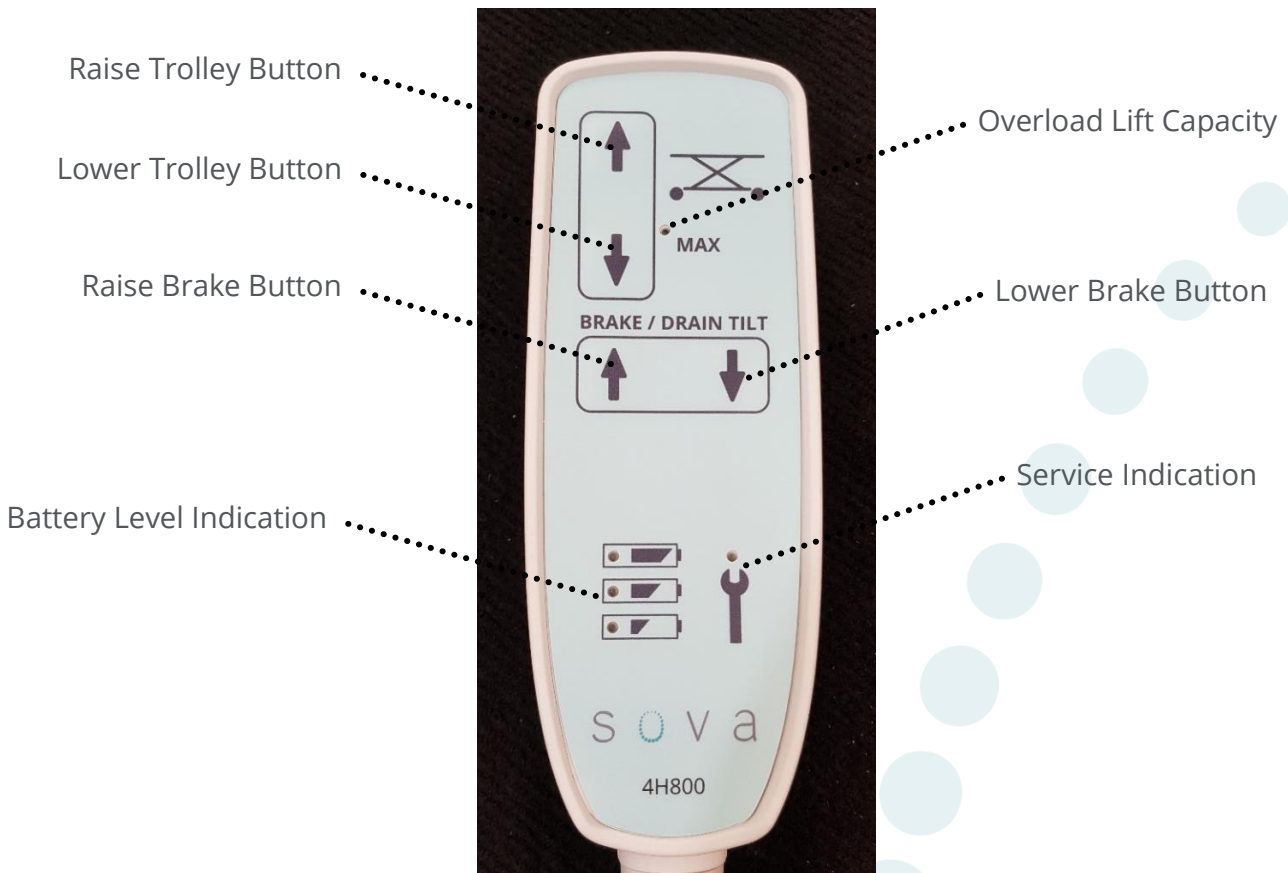

Handset - Fig. 4.4

## 5. Specifications

### 5.1. SWL

300kg

### 5.2. Dimensions

O/A Height: (low position) 520mm

O/A Width: 670mm

O/A Length: 2055mm

Trolley minimum reach height: 470mm

Trolley maximum reach height: 1680mm

## 6. Safety

### 6.1. General operation

- Use on level ground/surfaces.
- Ensure all wheel locks are applied while raising and lowering the Trolley.
- Ensure limbs and body parts are clear of trolley while raising and lowering.
- Do not lift anything other than a coffin or body tray.
- The trolley is designed for indoor use only.

### 6.2. Precautions

- Do not lift an unstable load.
- Do not lift on uneven ground/surface.
- Lower load to the lowest comfortable height to manoeuvre trolley for stability.
- Do not stand or climb on trolley.
- Do not use the trolley for any other purpose other than what it has been designed for.
- Do not exceed the 300kg lifting capacity.
- Ensure body tray or coffin are secure before manoeuvring trolley.
- Ensure weight is distributed symmetrically across the width of the trolley.
- Be aware of your surroundings while raising and lowering the trolley.
- Ensure nothing is caught under or above the trolley while raising and lowering.

## 7. Operation Instructions

### 7.1. Raise & Lower Trolley Operation

The Trolley can be raised or lowered in two ways by either the handset or by the control box.

To raise the trolley press and hold the up arrow button.

To lower the trolley press and hold the down arrow button



Handset - Fig.7.1-1



Control Box - Fig.7.1-2

### 7.2. Castor Operation

The trolley is fitted with both locking and directional castors. They can be identified by their colour. The red tabbed castors are total locking and the green tabbed castors are directional locking. Once the directional castor lock is engaged the castor will not swivel but the wheel is free to roll. The locking castor once engaged will prevent the wheel from rolling and swivelling.

- To engage the lock on a castor, press down on the colour tab at the back of the castor.
- To release the lock from the castor, press down on the highest part of the coloured tab.

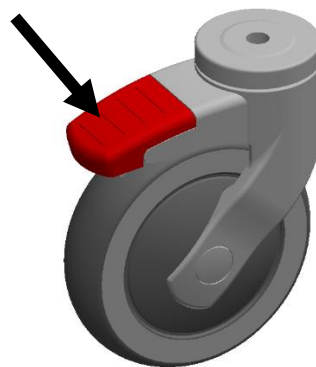

Castor - Fig. 7.2

### 7.3. Electric Brake Operation

The electric brake is used to prevent the body tray or coffin from rolling off the trolley.

The electric brake can be released or engaged in two ways by either the handset or by the control box.

To engage the lock press and hold the up button until the coffin or body tray raises off the rollers. Check the lock is engaged by pushing on the coffin or body tray to ensure it does not move.

To release brake press and hold the down button until the brake releases from the coffin or body tray.



Handset - Fig.7.3-1

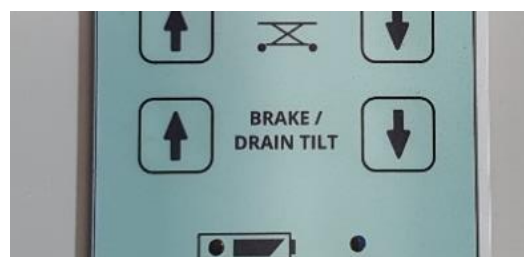

Control Box - Fig.7.3-2

### 7.4. Connecting & Disconnecting Battery

The battery is removable so it can be charged or interchanged with another battery.

To remove battery, use one hand to support the weight and the other to release the retaining clip located on the right side of the battery.

Battery - Fig. 7.4

## 7.5. Charging Battery

Remove battery from trolley and place on the charger, ensure the retainer clip is located onto the bracket.

Check the charging light and the power supply lights are on to ensure charging is in progress. When the battery is fully charged the charge light will turn green. This process generally takes 4 hours.

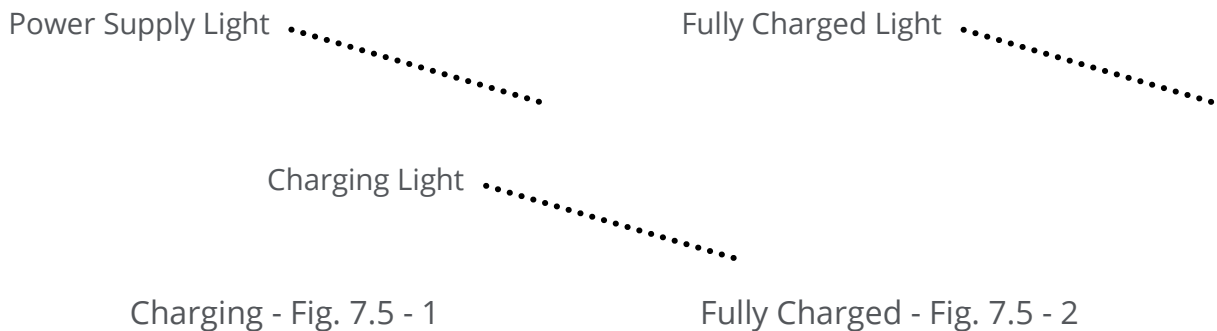

## 8. Care & Maintenance

### 8.1. Cleaning

- Wipe the trolleys surfaces with a soft cloth moistened with hot water and mild detergent (or the facilities recommended cleaning solution) It is recommended that the cloth be white to prevent bleeding of dye colours to the trolley. Take extra care in area that can harbor dirt and dust.
- Rinse with clean water and dry with a clean cloth.
- DO NOT use abrasive Hypocarbonate or Phenolic compounds or pads.
- DO NOT use acids, alkaline, or any other chemical solvents.
- DO NOT use agents which could alter the structure and behaviour of the power coat or any plastics. eg. petrol, toluene, acetone etc.

## 8.2. Maintenance

### Daily

- Visually check the trolley for any signs of damage
- Check that the handset and electrical features work correctly
- Check castors roll freely
- Check electric brake functions correctly

### Weekly

- Charge battery if not done daily as part of the routine

### Annually

- Check all fasteners, fixings and electrical components

If the Service light appears please contact SOVA as soon as possible.

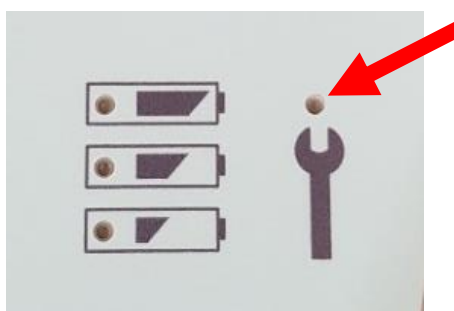

## 9. Transport & Storage

### 9.1. Storage

- If trolley is not being used for a long period of time SOVA recommends removing the battery and storing the trolley in a cool, dry well ventilated area out of direct sunlight.
- Store battery on charger while not in use.

### 9.2. Transport

- Lower trolley fully before transporting.
- Top load only.
- Transport on a pallet only.
- Do not drop and avoid shock or violent impacts when transporting.
- Remove battery and pack separately.

## 10. Warranty

SOVA warrants that its products are free from defects in workmanship, materials and will repair / replace defective components from the purchase date of the manufacture of the products. 5 years for framework.

All service and repairs must be carried out by SOVA or a certified SOVA trained Technician. SOVA will not be responsible for any expenses, inconvenience or incidental damages occasioned by the use, loss of use, or misuse of the products, or by failure of the products to conform to the warranty set forth above.

This warranty becomes void if the product shows evidence of mishandling, tampering, installation or use contrary to the application instruction material, shipping damage, or repair performed by other than a service personnel authorised by SOVA.

Routine cleaning, adjustment and normal cosmetic and mechanical wear are not covered by this warranty.

Prompt and written notice is required for a warranty claim.

No part of this publication may be reproduced without the prior written permission of SOVA Pty Ltd.

## 11. Spare Parts

Spare parts can be purchased from SOVA directly or through your local distributor.

**Tel:** (08) 9302 4757

**Email:** sales@sovamotion.com.au

<i>Image</i>	<b>Description</b>	<b>Part Code/Number</b>
	Castor - Locking - 150mm	CB150PT





Image	Description	Part Code/Number
	Castor - Directional - 150mm	CD150PT
	Dual Purpose Roller	800R
	Roller Axle	800RA
	Slide Bearing	800B
	Handset	45800H

Image	Description	Part Code/Number
	Control Box	4S800CB
	Battery	BHC24G-SOVA
	Lifting Actuator	4S800LA
	Brake Actuator	4S800BA
	Actuator Cable 2.5m	4S800AC

<i>Image</i>	Description	Part Code/Number
	Brake Tube	4S800BT
	Tube End Caps	803TEC

s o v a / dignity in motion

**Contact us**

**Tel:** (08) 9302 4757

**Email:** [sales@sovamotion.com.au](mailto:sales@sovamotion.com.au)

**[sovamotion.com.au](http://sovamotion.com.au)**

s o v a / dignity in motion